

Ascot 30

SKU 1486xxx

astro

INSTALLATION INSTRUCTIONS / INSTRUCTIONS D'INSTALLATION / INSTRUCCIONES DE INSTALACIÓN

EN PLEASE READ THE INSTRUCTIONS CAREFULLY

THIS PRODUCT MUST BE INSTALLED IN ACCORDANCE WITH THE APPLICABLE INSTALLATION CODE BY A PERSON FAMILIAR WITH THE CONSTRUCTION AND OPERATION OF THE PRODUCT AND THE HAZARDS INVOLVED. CONSULT A QUALIFIED ELECTRICIAN TO ENSURE CORRECT BRANCH CIRCUIT CONDUCTOR.

FR LIRE ATTENTIVEMENT LES INSTRUCTIONS AVANT DE COMMENCER LE MONTAGE

CE PRODUIT DOIT ÊTRE INSTALLÉ SELON LE CODE D'INSTALLATION PERTINENT, PAR UNE PERSONNE QUI CONNAÎT BIEN LE PRODUIT ET SON FONCTIONNEMENT AINSI QUE LES RISQUES INHÉRENTS. CONSULTER UN ÉLECTRICIEN QUALIFIÉ POUR VOUS ASSURER QUE LES CONDUCTEURS DE LA DÉRIVATION SONT ADÉQUATS.

ES LEA DETENIDAMENTE LAS INSTRUCCIONES

ESTE PRODUCTOR DEBE SER INSTALADO SEGUN EL CODIGO DE INSTALACION APLICABLE POR UNA PERSONA QUE CONOZCA LE CONSTUSSION Y EL FUNCIONAMIENTO DEL PRODUCTO Y LOS RIESGOS QUE SUPONE. CONSULTAR A UN ELECTRICISTA CALIFICADO PARA ASEGURAR LA ELECCION DEL CONDUCTOR DE CIRCUITO DERIVADO.

THIS DEVICE COMPLIES WITH PART 15 OF THE FCC RULES. OPERATION IS SUBJECT TO THE FOLLOWING TWO CONDITIONS:
(1) THIS DEVICE MAY NOT CAUSE HARMFUL INTERFERENCE, AND (2) THIS DEVICE MUST ACCEPT ANY INTERFERENCE RECEIVED, INCLUDING INTERFERENCE THAT MAY CAUSE UNDESIRE OPERATION

NOTE: THIS EQUIPMENT HAS BEEN TESTED AND FOUND TO COMPLY WITH THE LIMITS FOR A CLASS B DIGITAL DEVICE, PURSUANT TO PART 15 OF THE FCC RULES. THESE LIMITS ARE DESIGNED TO PROVIDE REASONABLE PROTECTION AGAINST HARMFUL INTERFERENCE IN A RESIDENTIAL INSTALLATION. THIS EQUIPMENT GENERATES, USES AND CAN RADIATE RADIO FREQUENCY ENERGY AND, IF NOT INSTALLED AND USED IN ACCORDANCE WITH THE INSTRUCTIONS, MAY CAUSE HARMFUL INTERFERENCE TO RADIO COMMUNICATIONS. HOWEVER, THERE IS NO GUARANTEE THAT INTERFERENCE WILL NOT OCCUR IN A PARTICULAR INSTALLATION. IF THIS EQUIPMENT DOES CAUSE HARMFUL INTERFERENCE TO RADIO OR TELEVISION RECEPTION, WHICH CAN BE DETERMINED BY TURNING THE EQUIPMENT OFF AND ON, THE USER IS ENCOURAGED TO TRY TO CORRECT THE INTERFERENCE BY ONE OR MORE OF THE FOLLOWING MEASURES:

- REORIENT OR RELOCATE THE RECEIVING ANTENNA.
- INCREASE THE SEPARATION BETWEEN THE EQUIPMENT AND RECEIVER.
- CONNECT THE EQUIPMENT INTO AN OUTLET ON A CIRCUIT DIFFERENT FROM THAT TO WHICH THE RECEIVER IS CONNECTED.
- CONSULT THE DEALER OR AN EXPERIENCED RADIO/TV TECHNICIAN FOR HELP. CHANGES OR MODIFICATIONS NOT EXPRESSLY APPROVED BY THE PARTY RESPONSIBLE FOR COMPLIANCE COULD VOID THE USER'S AUTHORITY TO OPERATE THE EQUIPMENT.

CAN ICES-005 (B) / NMB-005 (B)

Low voltage cabling shall not be accessible following installation/Le câblage basse tension ne doit pas être accessible après l'installation.

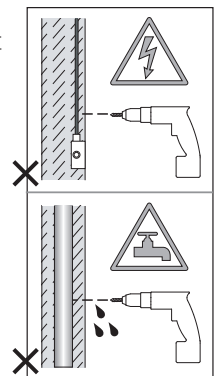

Product weight - 9.2kg
Poids du produit
Peso del producto



Two people required
Deux personnes sont nécessaires
Se requieren dos personas

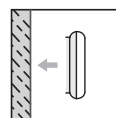

Wall mount only
Installation murale seulement
Exclusivamente para fijación en muro

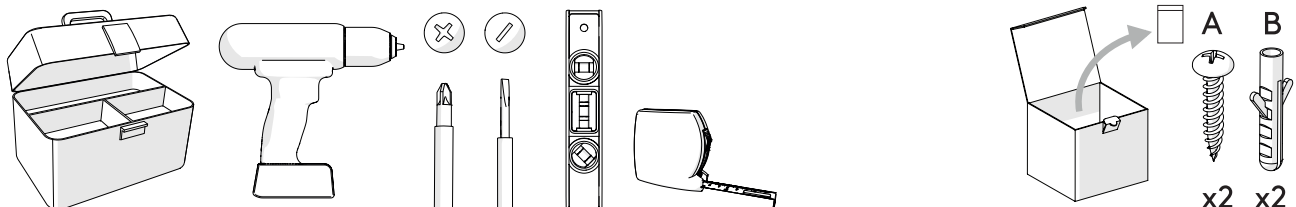

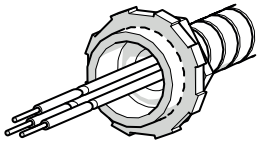

Hookup with MC whip
Rencontre avec le fouet MC
Conexión con MC whip

1

Electrical work should be performed with the power OFF on the respective circuit and be conducted by a licenced professional.

Les travaux électriques doivent être effectués avec le hors tension sur le circuit et être conduit par un professionnel agréé.

El trabajo eléctrico debe ser realizado con el apagado el respectivo circuito y ser conducido por un profesional con licencia.

2

A

200mm

B

Use a spirit level to align the raised fixings.

Utilisez un niveau à bulle pour aligner les fixations surélevées.

Utilice un nivel de burbuja para alinear las fijaciones elevadas.

3

4

Ensure an MC (Metal Clad) Whip is used between the Junction box and the Driver box. The whip must be secured using appropriate clamps. Listed/CN MC Cable secured to Driver Box and Junction Box with Listed/CN Fittings. MC (Metal Clad) Whip and fixings are not included.

Assurez-vous qu'un fouet MC (Metal Clad) est utilisé entre la Boîte de jonction et la boîte de conducteur. Le fouet doit être attaché à l'aide de pinces appropriées. Listé/CN MC Câble sécurisé à la boîte de conducteur et à la boîte de jonction avec les raccords répertoriés/CN. Le fouet MC (Metal Clad) et les fixations ne sont pas inclus.

Asegúrese de utilizar un látigo MC (revestido de metal) entre Caja de conexiones y caja del conductor. El látigo debe estar asegurado utilizando abrazaderas adecuadas. Cable MC listado/CN asegurado a la caja del conductor y la caja de conexiones con accesorios listados/CN. El látigo MC (Metal Clad) y las fijaciones no están incluidos.

5

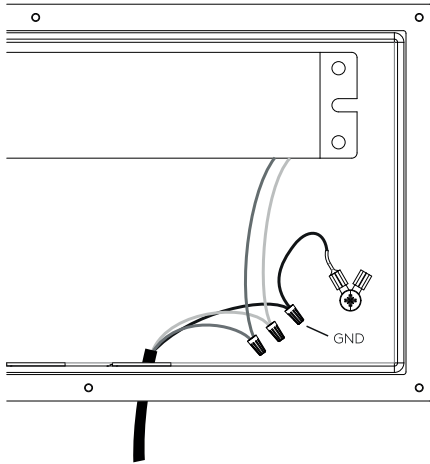

Ensure the connections of the MC Whip to the Driver Box and Junction/Outlet Box are made in accordance with the local national electrical code.

Assurer les connexions du MC Whip au Driver Box et la boîte de jonction/de sortie sont fabriqués conformément aux code électrique national local.

Asegúrese de las conexiones del MC Whip a la Driver Box y la caja de conexiones/salidas se fabrican de acuerdo con las código eléctrico nacional local.

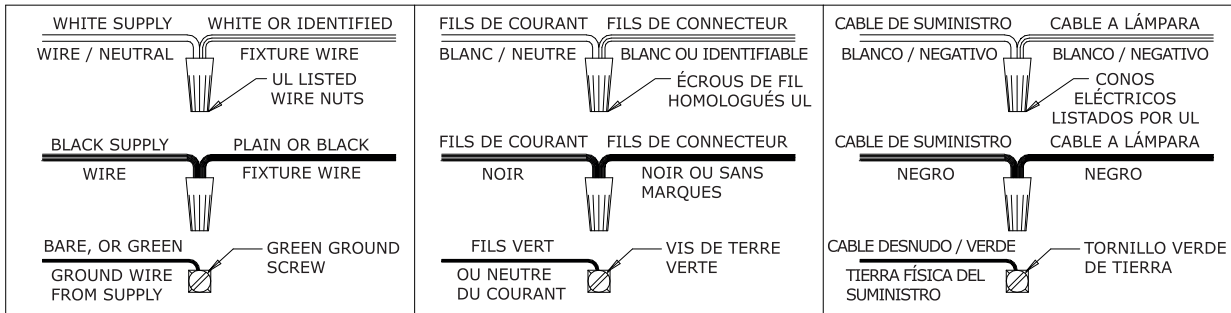

USE THE APPROPRIATE UL LISTED WIRE NUT FOR THE NUMBER OF CONDUCTORS IN THE INSTALLATION/
Utilisez l'écrou de fil homologué UL approprié pour le nombre de conducteurs dans l'installation/
Utilice el cono eléctrico apropiado listado por UL para la cantidad de conductores en la instalación

6

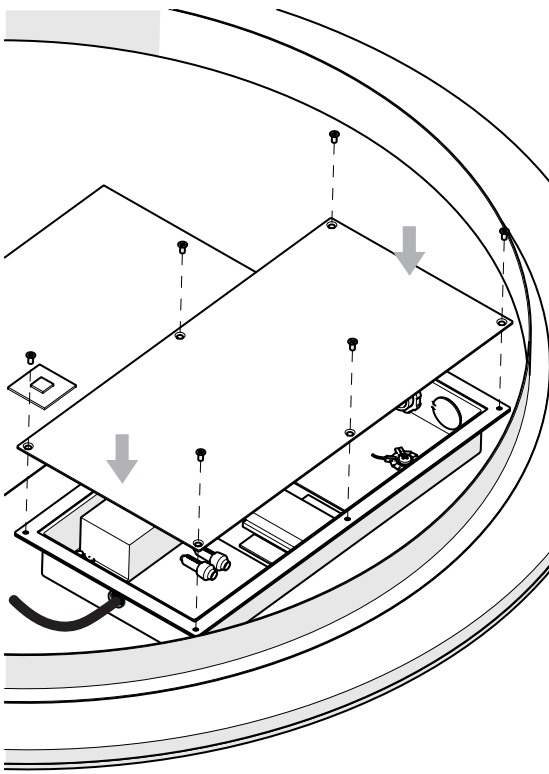

7

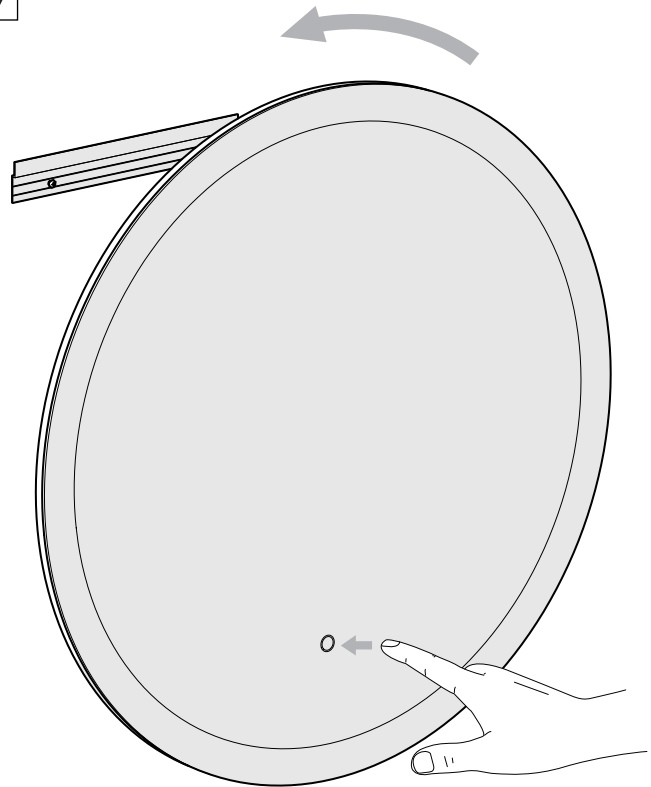

2700k  6000k